

OmniAccess Supervisor Card III

Installation Guide

Introduction

The OmniAccess Supervisor Card III (OAW-S3) is a hot-swappable module for use within an OAW-6000 modular based WLAN Switch system utilizing 400 W power supplies. The OAW-6000 is capable of containing up to four OAW-S3 modules, each of which can be configured as a master or local switch. The OAW-S3 is also compatible with existing Alcatel-Lucent line cards and supervisor cards. The OmniAccess Supervisor Card 1 and OmniAccess Supervisor Card II, earlier generation supervisor cards, will hereinafter be referred to as OAW-SC. For compatibility and configuration options, refer to [Configuration Options on page 6](#).

OAW-S3 Options:

- OAW-S3-0-2X10G (base model; no built-in AP support; optional Alcatel-Lucent AP upgrade licenses available)
- OAW-S3-C-2X10G (includes built-in campus connected AP support of up to 128 APs; additional Alcatel-Lucent AP upgrade licenses available)

OAW-S3 modules are capable of supporting up to 512 campus connected APs with the use of Alcatel-Lucent AP upgrade licenses. Contact your Alcatel-Lucent sales representative for a complete listing of available software licenses.

Minimum Software Requirements

The OAW-S3 requires a full distribution release of AOS-W 3.2.0 or later.

AOS-W software builds prior to version 3.2.0 do not support OAW-S3 modules. If your network currently runs on a software build prior to 3.2.0, you must upgrade the software on your master and local switches to 3.2.0 or later prior to installing an OAW-S3 in your existing network.



CAUTION

If you install an OAW-S3 into an OAW-6000 with an existing OAW-SC running a version of software prior to 3.2.0, the existing supervisor card may fail. You must upgrade the software on the existing supervisor card prior to installing an OAW-S3.



NOTE

The master switch, its redundant master switch, and all of its local switches must run on the same code of AOS-W. Once you upgrade your network and install an OAW-S3 module into your network, verify that the software version on your OAW-S3 matches the rest of the network. If the code shipped on the module is prior to the version that you upgraded your network to, you must upgrade the code on the OAW-S3 to match the rest of the network.

Package Checklist

- OmniAccess Supervisor Card III
- *OmniAccess Supervisor Card III (OAW-S3) Installation Guide*



Inform your supplier if there are any incorrect, missing, or damaged parts. If possible, retain the carton, including the original packing materials. Use these materials to repack and return the unit to the supplier if needed.



Optional accessories, such as SFP and XFP modules, are available for use with the OAW-S3 and are sold separately. Contact your Alcatel-Lucent sales representative for details and assistance.

Hardware Overview

Figure 1 *OmniAccess Supervisor Card III (OAW-S3)*

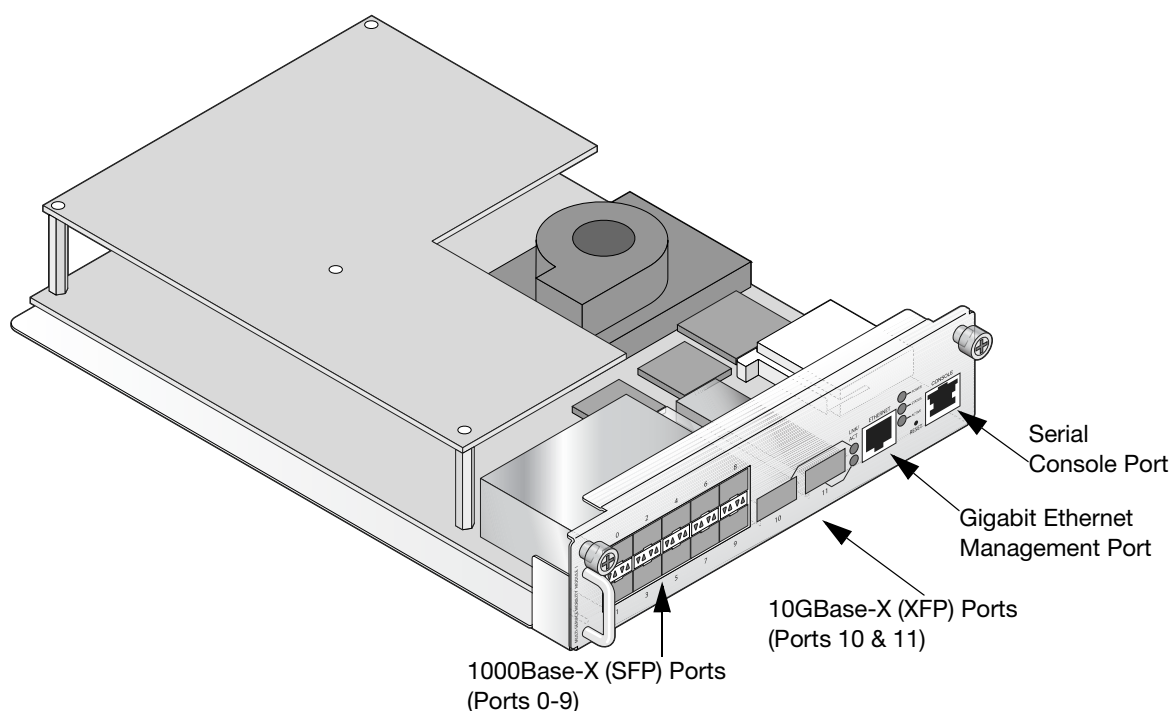

Ports

1000Base-X (SFP) Ports

Ports 0 through 9 on the OAW-S3 are 1000Base-X (SFP) ports for fiber or copper connectivity and are intended for use with Alcatel-Lucent approved SFPs.



Alcatel-Lucent tests and supports Alcatel-Lucent approved optics within their switch systems. Non-approved, third party optics are not tested or supported; therefore, Alcatel-Lucent does not guarantee proper functionality of non-approved, third party optics when used in an Alcatel-Lucent system. For a complete list of Alcatel-Lucent approved optics, contact your Alcatel-Lucent sales representative. For further details regarding Alcatel-Lucent approved SFPs, such as technical specifications and installation instructions, refer to the *Alcatel-Lucent SFP Optical Modules Installation Guide*.

10GBase-X (XFP) Ports

Ports 10 and 11 on the OAW-S3 are 10GBase-X fiber optic ports for use with Alcatel-Lucent XFPs. XFPs are 10 Gbit hot-swappable, optical transceivers, which convert serial electrical signals to external serial optical or electrical signals.



Alcatel-Lucent tests and supports Alcatel-Lucent approved optics within their switch systems. Non-approved, third party optics are not tested or supported; therefore, Alcatel-Lucent does not guarantee proper functionality of non-approved, third party optics when used in an Alcatel-Lucent system. For a complete list of Alcatel-Lucent approved optics, contact your Alcatel-Lucent sales representative. For further details regarding Alcatel-Lucent approved XFPs, such as technical specifications and installation instructions, refer to the *Alcatel-Lucent XFP Optical Modules Installation Guide*.

Gigabit Ethernet Management Port

This port is a 10/100/1000Base-T Gigabit Ethernet (RJ-45) port. Gigabit Ethernet uses all eight wires and each pair is used in a bi-directional fashion, meaning the same pairs are used for both data transmission and reception. This port also supports Auto MDIX, allowing the use of crossover or straight through cables. [Figure 2](#) illustrates the CAT-5 pin-out found on an RJ-45 connector. The CAT-5 pin-out pairs the following pins on a 10/100/1000Base-T Gigabit Ethernet port: 1/2, 3/6, 4/5, and 7/8.



Ethernet traffic on this port is out-of-band; this port is segmented from regular switching and routing functions and cannot be used as a network data port.

Figure 2 Gigabit Ethernet Port Pin-Out

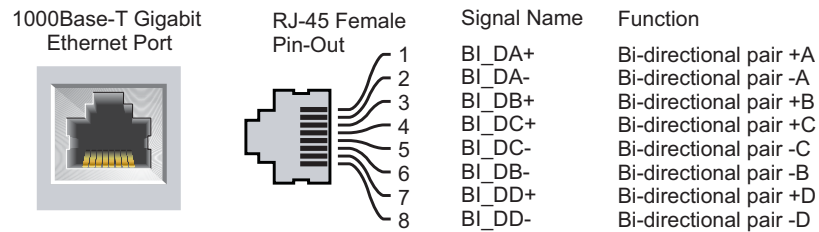

Serial Console Port

A serial console port is provided for connection to a terminal, allowing for direct local management. The port's RJ-45 female connector accepts an RS-232 serial cable with a male connector.

Figure 3 Serial Console Port Pin-Out

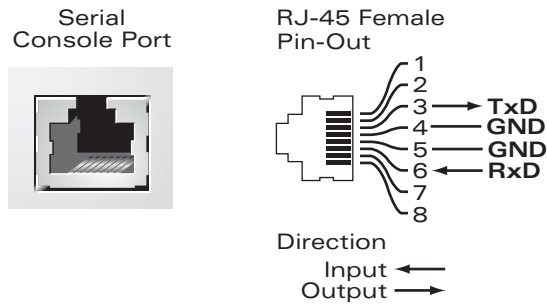

Communication settings for the serial console port are indicated in [Table 1](#).

Table 1 Console Terminal Settings

Baud Rate	Data Bits	Parity	Stop Bits	Flow Control
9600	8	None	1	None



Do not connect an Access Point (AP) to the serial console port. The serial console port is only compatible with RS-232 devices. Non-RS-232 devices, such as APs, are not supported and will cause the switch to fail.

Serial Console Port Adaptor

A modular adaptor can be used to convert the RJ-45 (female) connector to a DB9 (male) connector. Refer to [Figure 4](#) for complete details.

Figure 4 RJ-45 (female) to DB9 (male) Modular Adaptor Conversion

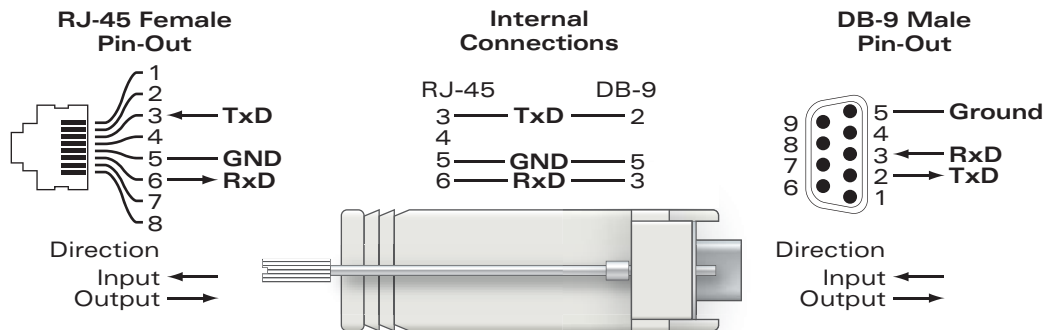

LED Status Indicators

Table 2 describes the OAW-S3 LEDs and their function.

Table 2 OAW-S3 LED Status Indicators

LED	Function	Indicator	Status
POWER	Input Power Status	On (Green)	Power on
		Off	No power
STATUS	Module Status Indicator	On (Green)	Device is operational
		On (Amber)	Device is booting
		On (Red)	Device failed
		Off	Device is loading software or no power
ACTIVE	Module Mode Indicator	On (Green)	Device in active mode
		On (Yellow)	Device in standby mode
		Off	Device has not determined operating state or no power
LNK/ACT	Link Status Indicator	On (Solid Green)	Link has been established
		On (Flashing Green)	Port is transmitting or receiving data
		Off	No link on port

Configuration Options

Configuration Requirements

The following requirements must be adhered to when running OAW-S3 modules within an OAW-6000:

- An OAW-S3 (or OAW-SC) must be installed in Slot 0 or Slot 1. OAW-S3 modules in Slot 2 or Slot 3 will not boot if an OAW-S3 (or OAW-SC) is not present in Slot 0 or Slot 1. Refer to [Figure 5](#) for Slot ID and locations within an OAW-6000.
Slot 0 or Slot 1 must be populated first since backplane communication occurs between the following: Slot 0 communicates with Slot 2 and/or Slot 3, and Slot 1 communicates with Slot 2 and/or Slot 3.
- The OAW-S3 is designed for installation within an OAW-6000 utilizing 400 W power supplies only. OAW-S3 modules will not boot within an OAW-6000 utilizing 200 W power supplies. Refer to [Power Management on page 9](#) for complete details.
- Minimum software requirements must be met prior to installing an OAW-S3. Refer to [Minimum Software Requirements on page 1](#) for complete details.

Figure 5 OAW-6000 Slot Configuration

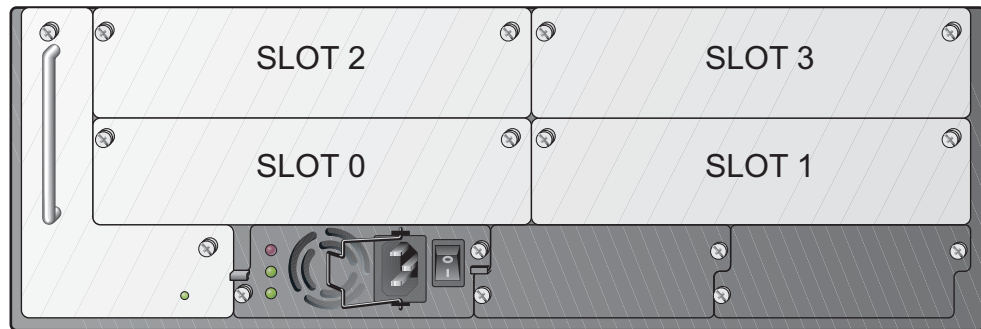

Compatibility and Configuration Options

OAW-S3 modules are compatible with existing Alcatel-Lucent line cards and supervisor cards. Specific combinations of these devices can run within the same OAW-6000.

To avoid confusion when mixing and matching modules, follow these installation and configuration guidelines:

- Keep in mind that an OAW-S3 or OAW-SC must always be present in Slot 0 and/or Slot 1. Therefore, populate your OAW-S3 and/or OAW-SC in the lowest numbered slot first and move upward. Slot 0 or Slot 1 must be populated first since backplane communication occurs between the following: Slot 0 communicates with Slot 2 and/or Slot 3, and Slot 1 communicates with Slot 2 and/or Slot 3.
- Line cards require communication with an OAW-S3 or OAW-SC and should be installed after your OAW-S3 and/or OAW-SCs are in place. When installing line cards, populate the highest numbered slot first and work downward.



The OAW-S3 only supports 802.3af Power over Ethernet (PoE) when managing the following Alcatel-Lucent line card: OAW-LC-2G24FP.

- Configuration options are also dependent on power requirements for each module. Refer to [Power Management on page 9](#) for complete details.

Installation

Pre-Installation Requirements

The following tools and equipment are required for installation of an OAW-S3 module:

- Pre-installed OAW-6000 (sold separately)
- ESD-preventive wrist strap (not provided)
- #2 Phillips screwdriver (not provided)
- OAW-S3 module(s)

Physical Installation

To install an OAW-S3 module into an OAW-6000:

1. Use standard ESD precautions when installing an OAW-S3.
2. Remove the blank front panel or existing module from the appropriate slot in the OAW-6000 (if applicable).



Alcatel-Lucent recommends the use of a blank front panel over any unused slots in an OAW-6000. The blank front panel is required for proper cooling and air flow within the OAW-6000.

3. Remove the OAW-S3 from the shipping carton and ESD bag.
4. Slide the OAW-S3 into the OAW-6000 using the guide rails. The OAW-S3 must be seated within the guide rails for proper installation (see [Figure 6](#)).

Figure 6 *Installing an OAW-S3*

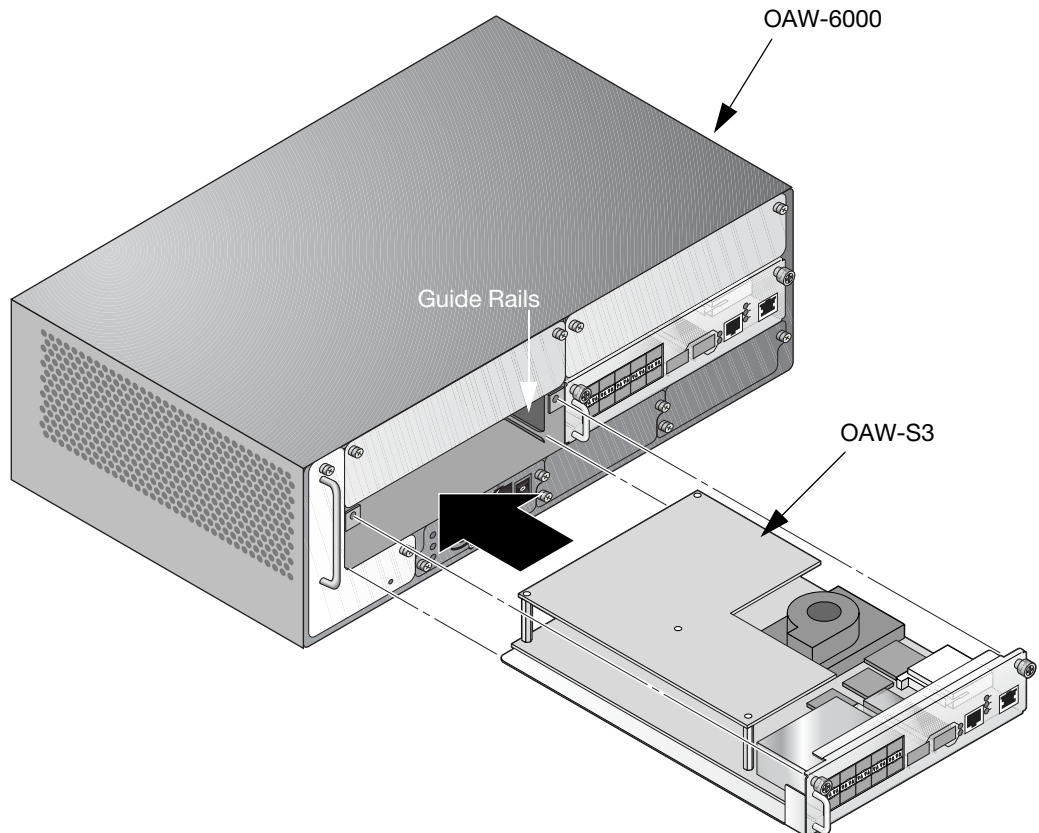

5. Secure the OAW-S3 to the OAW-6000 by tightening down the two captive screws using a #2 Phillips screwdriver (see [Figure 7](#)). Turn the captive screws clockwise until the screws are hand tight. Do not over-tighten the screws.

Figure 7 *Securing an OAW-S3*

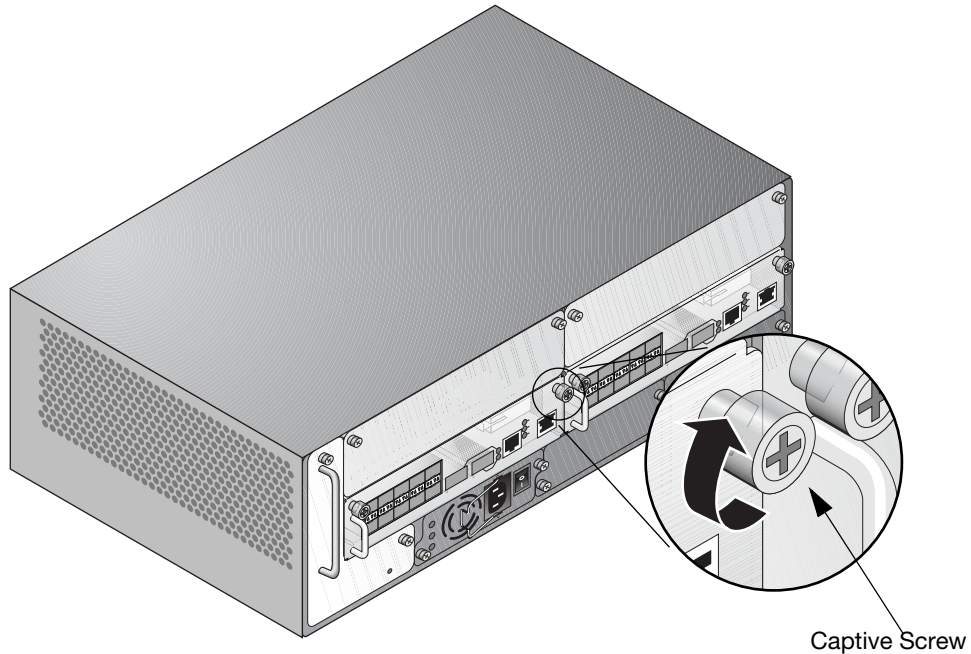

Initial Setup and Network Connectivity

Once the physical installation is complete, run the initial setup on the OAW-S3 to configure the IP address of the module (referred to as the switch in AOS-W documentation) and other basic system information. For complete details and instructions, refer to the *AOS-W Quick Start Guide* for the software version installed on your switch.

Removal

1. Use standard ESD precautions when removing an OAW-S3.
2. Turn the captive screws counter-clockwise to loosen the screws and release the OAW-S3.
3. Slide and remove the OAW-S3 from the OAW-6000.
4. Install a blank front panel over any unused slots.



Alcatel-Lucent recommends the use of a blank front panel over any unused slots in an OAW-6000. The blank front panel is required for proper cooling and air flow within the OAW-6000.

Power Management

The OAW-6000 supports up to three 400 W power supplies. If utilizing three primary power supplies for 1200 W of primary power, redundancy is not supported. If using one to two primary power supplies for 400 to 800 W of primary power, the use of a 400 W redundant power supply is possible.

Power calculations are based on the maximum power draw for each module:

- OmniAccess Supervisor Card III (OAW-S3): 130 W
- Line Card without SPoE (OAW-LC-2G, OAW-LC-2G24F): 40 W
- Line Card with SPoE (OAW-LC-2G24FP): 400 W
- OmniAccess Supervisor Card I and II (OAW-SC-1-48, OAW-SC-1-128, and OAW-SC-2-256): 40 W

For maximum capacity planning, add the maximum power draw required for all of the modules in your chassis configuration to determine the required number of power supplies. If the maximum power draw exceeds 1200 W, the configuration is not supported. For instance, three line cards with SPoE and an OAW-S3 would require 1330 W of power, which exceeds maximum power supply capabilities.

Common OAW-S3 Configuration Examples

Table 3 Power Requirements for Common Configurations

Module	Number of Units															
OAW-S3 130 W max power draw	1	1	1	1	1	1	1	2	2	2	2	2	3	3	3	4
OAW-LC- 2G or OAW- LC-2G24F 40 W max power draw	0	1	2	3	0	0	0	0	1	2	0	0	0	1	0	0
OAW-LC- 2G24FP 400W max power draw	0	0	0	0	1	2	3	0	0	0	1	2	0	0	1	0
Primary 400 W PSU	1	1	1	1	2	3	*N/S	1	1	1	2	3	1	2	2	2
Redundant 400 W PSU	1	1	1	1	1	0	*N/S	1	1	1	1	*N/S	1	1	1	1
Total Power (W)	130	170	210	250	530	930	1330	260	300	340	660	1060	390	430	790	520

*N/S: Not supported

Note: Configuration options including supervisor cards are not included in the above table.

Safety and Regulatory Compliance

Alcatel-Lucent provides a multi-language document containing country specific restrictions and additional safety and regulatory information for Alcatel-Lucent hardware products. The *Alcatel-Lucent Safety and Regulatory Addendum* can be viewed or downloaded from the following location: <https://service.esd.alcatel-lucent.com>.



Use of controls or adjustments of performance or procedures other than those specified in this manual may result in hazardous radiation exposure.

This product complies with 21 CFR Chapter 1, Subchapter J, Part 1040.10, and IEC 60825-1: 1993, A1: 1997, A2: 2001, IEC 60825-2: 2000.

For continued compliance with the above laser safety standards, only approved Class 1 modules from our approved vendors should be installed in Alcatel-Lucent products.

Proper Disposal of Alcatel-Lucent Equipment

For the most current information on Global Environmental Compliance and Alcatel-Lucent products please see our website at www.alcatel-lucent.com.

Waste of Electrical and Electronic Equipment

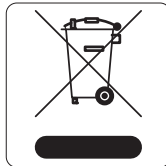

Alcatel-Lucent products at end of life are subject to separate collection and treatment in the EU Member States, Norway, and Switzerland and therefore are marked with the symbol shown at the left (crossed-out wheellie bin). The treatment applied at end of life of these products in these countries shall comply with the applicable national laws of countries implementing Directive 2002/96EC on Waste of Electrical and Electronic Equipment (WEEE).

European Union RoHS



Alcatel-Lucent products also comply with the EU Restriction of Hazardous Substances Directive 2002/95/EC (RoHS). EU RoHS restricts the use of specific hazardous materials in the manufacture of electrical and electronic equipment. Specifically, restricted materials under the RoHS Directive are Lead (including Solder used in printed circuit assemblies), Cadmium, Mercury, Hexavalent Chromium, and Bromine. Some Alcatel-Lucent products are subject to the exemptions listed in RoHS Directive Annex 7 (Lead in solder used in printed circuit assemblies). Products and packaging will be marked with the "RoHS" label shown at the left indicating conformance to this Directive.

China RoHS



Alcatel-Lucent products also comply with China environmental declaration requirements and are labeled with the "EFUP e" label shown at the left.

Contacting Alcatel-Lucent

Web Site Support	
Main Site	http://www.alcatel-lucent.com/wps/portal/enterprise
Support Site	https://service.esd.alcatel-lucent.com
Support Email	support@ind.alcatel.com

Telephone Support	
North America	1-800-995-2696
Latin America	1-877-919-9526
Europe	+33 (0) 38 855 6929
Asia Pacific	+65 6586 1555/1-818-878-4507
Worldwide	1-818-880-3500



www.alcatel-lucent.com
26801 West Agoura Road
Calabasas, CA 91301

Copyright © 2007 Alcatel-Lucent. All rights reserved.